

Evaluation of Heterodyning and Interpolation for Signal Generation of TIGER Transmitter

T.Salim (t.gill@ee.latrobe.edu.au), J.Devlin., J.Whittington.,
Department of Electronic Engineering
La Trobe University Bundoora, VIC 3086 Australia

Abstract

The Tasman International Geospace Environment Radar (TIGER) is a high latitude ionospheric radar monitoring a region of the ionosphere south of Australia. Currently we are designing a second radar using the digital technology and reconfigurable devices as replacement for the traditionally analogue transmitter, phasing matrix and receiver of the radar. A method for the digital generation of a Gaussian modulated signal using multirate techniques has previously been presented. In this paper, two implementations of the digital signal generation are discussed, one using FIR implementation and the other using polyphase interpolation. These methods differ from conventional analog heterodyning techniques through the use of time variant signal processing for frequency translation. We compare these two techniques, considering different performance parameters including computations and non-linear effects on system performance.

1. Introduction

SuperDARN (Super Dual Auroral Radar Network) is an international radar network, which evaluates the space weather system. The Tasman International Geospace Environment Radar (TIGER) is one component of the SuperDARN network that analyzes the space weather in the Southern Hemisphere. This radar commenced operation in December 1999 and is successfully analyzing ionospheric irregularities. The operating frequency and beam selection procedure of the transmitter is controlled by computer over a local area network. The transmitted pulses are modulated using analog heterodyne operations and each of the sixteen transmitter antennas is fed by a separate power transmitter module [1]. The proposed system will keep the analog power transmitter, with the low level signal processing being implemented in the digital domain.

By moving the entire transmitter signal generation including frequency synthesis to the digital domain we gain significant benefits

- Significant reduction in equipment requirements and size.
- System reliability (in particular the phasing matrix) is greatly improved which also reduces maintenance and calibration requirements and cost.

In this paper we present two alternate methods for the digital generation of the fixed RF signals for the sixteen power amplifiers. The first method involves conventional techniques to digitally heterodyne and phase shift signals before conversion to the analog domain. The second method uses an interpolation filter to implement the phase and frequency shifting.

2. Modulation Schemes in Signal Generation

In conventional transmitters a balanced mixer and analog filters are used for frequency translation or channelization. The frequency resolution of the analog synthesizer depends on the required application. Analog components introduce distortion in the signal. These effects are related to the non-uniform gain and phase of analog filters and imbalance in the modulation process. The nonlinearities caused by the analog systems also include DC offset, intermodulation terms from the mixing processes and non-linear amplitude responses of different circuit elements [2]. These distortions can mostly be mitigated using Digital Signal Processing (DSP) techniques.

In first generation digital communication systems the baseband processing is digital while RF signals are still in the analog domain. In the transmitter section a Digital to Analog Converter (DAC) is used to convert the digital baseband signal to analog before mixing and filtering to produce the transmitted signal. The analog mixers and analog filters create distortion in the signal. These effects may be temperature and time dependent therefore they are not completely eliminated with analog filtering and conditioning. Some of these distortions can be reduced with DSP techniques which can be applied at reduced sampling rates.

Second generation transmitters put the DAC after the mixer. The mixing operation is then performed in the digital domain which reduces some of the distortion resulting from analog components. Intermodulation terms and mismatching problems are eliminated in the digital section using DSP techniques. Mixing in the digital domain also eliminates the DC injection problem. The disadvantage of this class of transmitter is the high rate of computations which are involved in processing the sine or cosine multiplication.

In third generation transmitters, intentional aliasing is used for IF translation. This class of modulator does not need any mixing, Direct Digital Synthesizer (DDS) or a sine or cosine generator. Multirate processing is used to provide

the heterodyne operation in the digital domain. We present a comparison of implementation using the second and third generation techniques for a TIGER transmitter in the following section.

3. Heterodyning Method

In conventional heterodyning techniques the modulating signal is mixed with a carrier. The information may be transmitted using amplitude, frequency or phase modulation. For our case amplitude modulation is considered. There are many ways to create an AM modulated signal. In one of the methods the final AM modulation envelope contains three frequency components two side bands and one carrier. In some applications the carrier is eliminated to save the modulated energy. In SSB only one sideband is transmitted since both sidebands contains identical information and the energy is concentrated in the signal.

A block diagram of a quadrature amplitude modulation scheme is shown in Figure 1. Gaussian pulses are mixed with the carrier frequency after a pulse shaping procedure involving matched filtering. Quadrature sinusoids are supplied by a Direct Digital Frequency Synthesizer (DDFS) of a suitable resolution. The frequency shifting is done by a sinusoidal multiplier and a complex bandpass filter is applied to select the desired band. The digital signal is then transformed into the analog domain using a DAC. This block diagram can be used to generate an RF signal for one of the sixteen TIGER transmitters. The rest of the transmitters will be identical with the exception of a phase delay. A constant time vector can be inserted before the DAC to introduce phase angles for each signal.

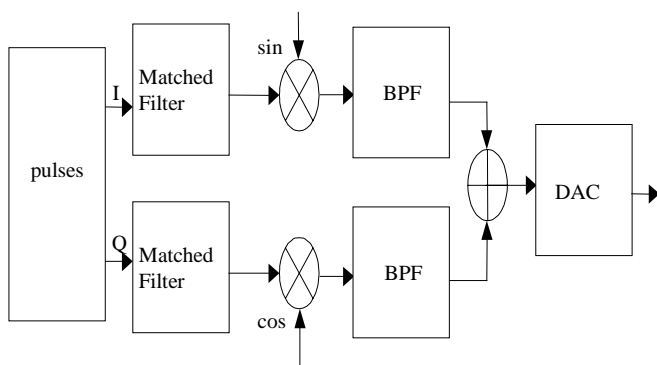

Figure 1 Conventional heterodyning digital modulator

Simulation results have been modeled with a digital mixer and sampled Gaussian pulses. The signal envelope of the modulated signal is shown in Figure 2. The time domain pulse is displayed with normalized time of one symbol period. Figure 3 shows the spectrum of the AM modulated signal with carrier. The frequency response contains three components which represent two side bands and a carrier

frequency. For simplicity the results are illustrated for the real part of the modulator only.

A disadvantage of this method is the higher computation load on the digital mixer since it operates at the very high sampling rate of the RF signal. The problem is significant when a hardware implementation is to be considered. In DSP hardware, multiplication is the speed bottle neck and a cause of quantization errors when a limited number of bits are used rather than the floating point arithmetic of simulations. After heterodyning of the modulated signal a bandpass filter is still required to suppress the unwanted spectral image. In the next section an alternative technique is presented that solves some of these problems.

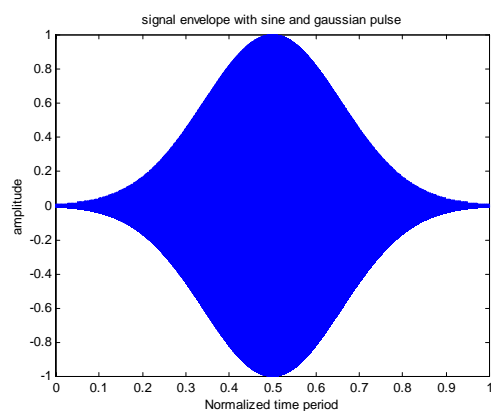

Figure 2 Signal envelope after mixing

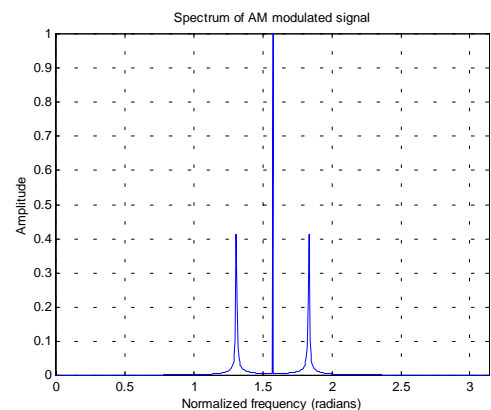

Figure 3 Amplitude modulation, f_c is $\pi/2$ and modulating signal contains frequency of $\pi/12$.

4. Interpolation Method

In this method signal generation is based on a digital filter and interpolation. The input gaussian pulse is upsampled which means the spectrum now contains multiple periodic copies or higher order Nyquist zones [3]. A narrow band filter is used to remove unwanted spectral images. The

problem with upsampling is multiple spectral copies covering the whole available bandwidth. This method is not suitable for multicarrier modulation where an adjacent channel carries valid information. In radar systems no such type of orthogonal or multiband restrictions exist, therefore this method works very well. In this system, signal generation contains frequencies in the range of 8 to 20 MHz. The operational frequency is selected from this band with a bandwidth of 10 kHz. Spectral images outside this band are not significant enough to cause any substantial interference to the operational band.

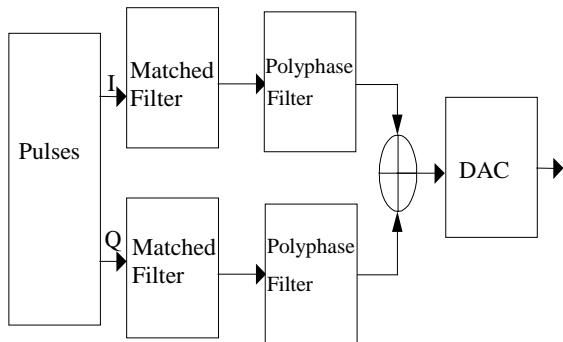

Figure 4 Digital modulator with interpolation

The block diagram of the multirate modulator is shown in Figure 4. Now the mixing process is performed using a polyphase interpolator. The signal after matched filtering is up sampled to produce spectral copies of the input signal. For example, a 10MHz signal is generated using a Gaussian shaped carrier input at 250KHz. This input is upsampled by a factor of 40 with a 20MHz sampling rate. A high pass FIR filter response is implemented as a polyphase filter to acquire a spectral copy at the highest band edge. Polyphase filters are computationally efficient since they operate on a lower sampling rate relative to an equivalent FIR filter. The complex output is converted into the analog domain using a high throughput DAC. Phasing of each signal can be implemented with another polyphase filter before the DAC or possibly even incorporated into the same polyphase filter. In the next section the implementation of the polyphase filter is discussed for interpolation.

4.1 Polyphase implementation of FIR Filters

Polyphase filters are being increasingly used largely due to their efficient use of resources when implemented in hardware. Fig 5 illustrates the working principle of a polyphase filter. The filter impulse response of an N tap FIR can be divided into L sub-filters, where L is the upsampling factor.

We consider an example of a 200 tap FIR filter that operates on a resampled Gaussian pulse with an upsampling factor of ten. The FIR filter response is now decimated to a polyphase network of twenty sub-filters each containing ten taps. Each branch of the polyphase filter contributes to one nonzero sample at the output, which is one of ten of the newly upsampled signal. The advantage of a polyphase filter is that it performs filtering at a low sampling rate [4]. The filter coefficients of the polyphase filter can be written as

$$h_p[n] = h[nL + p]$$

Where $h_p[n]$ are polyphase filter coefficients and L is the upsampling factor. As can be seen from Figure 5 for each new input sample there are twenty output samples.

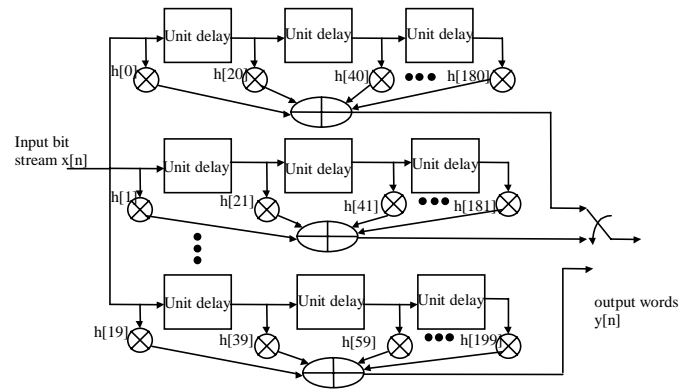

Figure 5 Polyphase implementation of 200 taps FIR filter

Simulations have been performed to model the signal envelope and its spectrum. Figure 6 shows the modulation envelope with a polyphase filter of 200 taps. Firstly the Gaussian pulse is shown with an upsampling factor of ten and resultant spectral copies are displayed within the band of π normalized radians. The FIR filter of length 200 taps is divided into polyphase subsections. Each subfilter contains 10 taps and there are twenty such filters in total. The modulation envelope and spectrum of the filtered signal, after the polyphase operation, is displayed in Figure 6 (b). Clearly a spectral copy is achieved without much attenuation.

5 Discussion

A comparison of conventional heterodyning and multirate signal generation has been presented in the digital domain. It has been concluded that DSP methods with time varying processing are more efficient for hardware implementation. The computations and calculations for signal generation are significantly less in the later case. Currently we are investigating methods to implement these signal generation algorithms onto reconfigurable Field Programmable Gate Array (FPGA) devices.

Acknowledgements

The authors wish to thank reviewers for helpful comments.

References

- [1] Raymond A. Greenwald, 'Space Weather, SuperDARN and the Tasmanian Tiger', *Australian Journal of Physics*, Vol. 50, Iss. 4, pp. 773-92, 1997.
- [2] Fred Harris, 'Signal Processing in Next Generation Digital Receivers and Transmitters', *DSP World Spring Design Conference*, April 26-28, Santa Clara, CA.
- [3] L. P. Sabel and F. J. Harris, 'Using the High order Nyquist Zones in the Design of Efficient Multi-Channel Digital Upconverters', *IEEE PIMRC*, Helsinki, Finland, September 1997.
- [4] Ronald E. Crochiere and Lawrence R. Rabiner, 'Interpolation and Decimation of Digital Signals- A Tutorial Review', *Proceedings of the IEEE*, Vol. 69, No.3 March 1981, pp.300-31.
- [5] T.Salim., J.Devlin., J.Whittington., 'Investigation of multirate techniques for digital generation of Transmitter signals for TIGER Radar', Accepted for publication by IEEE INMIC Conference to be held in Lahore, Pakistan.

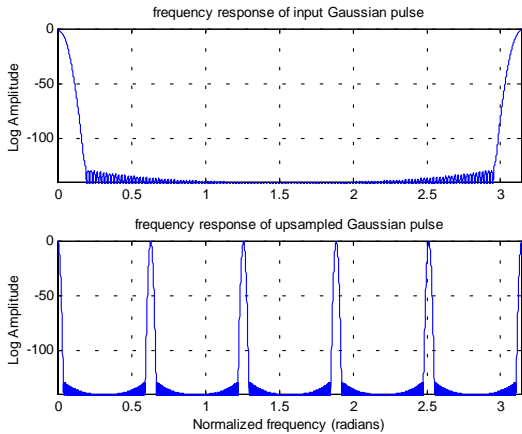

(a)

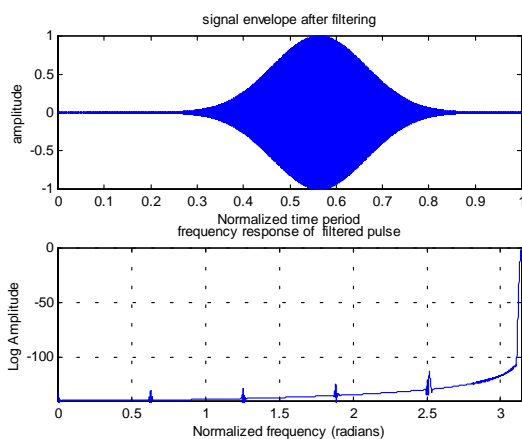

(b)

Figure 6 Modulation using interpolation method, (a) upsampling process and (b) polyphase implementation

The advantage of polyphase filters is that they combine the upsampling and filtering process into a single stage [5]. From the hardware implementation point of view this puts less load on the hardware resources needed to implement the convolution operation, as the input gaussian pulses are convolved with the impulse response of the filter. Secondly after interpolation, which is equivalent to mixing in conventional systems, no filter is required to filter unwanted frequency components. Another important point is the symmetric property of the FIR filter that may save almost half the computations. More processing can be saved if the hardware algorithm is modeled to save computations in the interpolation process since this trivial process only inserts zeros between the signal samples.